

## Shear Behavior of Panel Zone Considering Axial Force for Flanged Cruciform Columns

Sarfarazi, S.<sup>1</sup>, Saffari, H.<sup>2\*</sup> and Fakhraddini, A.<sup>3</sup>

<sup>1</sup> M.Sc., Department of Civil Engineering, Graduate University of Advanced Technology, Kerman, Iran.

<sup>2</sup> Professor, Department of Civil Engineering, Shahid Bahonar University of Kerman, Kerman, Iran.

<sup>3</sup> Ph.D., Department of Civil Engineering, Shahid Bahonar University of Kerman, Kerman, Iran.

Received: 26 Jul. 2019;

Revised: 09 Mar. 2020;

Accepted: 14 Mar. 2020

**ABSTRACT:** Panel zone is a part of a column web where surrounded by the continuity plates and the column flanges. Panel zone plays a vital role in the connection behavior. Despite the upward tendency of using cruciform section in many seismic regions, few studies have focused on the behavior of these columns, and especially on the behavior of their panel zone. As well, some recent studies have shown that axial load has a remarkable effect on the yielding process of the panel zone. In this research, a mathematical model is presented to consider the effect of axial force on the behavior of the panel zone in the cruciform columns. The model included the shear stiffness of the panel zone in the elastic and non-elastic region, the yield shear and the ultimate shear capacity of the panel zone. Consequently, 432 Finite Element Models (FEM) in a wide range of dimensions are performed and a parametric study has been done. The comparisons of the results of proposed mathematical model with the results of all Finite Element models demonstrate that the average and maximum deviation for yield and ultimate shear strength of the panel zone are respectively 5.32%, 8.12%, 6.2%, and 8.44%. This matter exhibits the accuracy and efficiency of the proposed mathematical relations.

**Keywords:** Axial Force, Beam To Column Connection, Cruciform Column, FEM, Panel Zone.

### INTRODUCTION

A column is one of the main components of two orthogonal moment resisting frames. The columns are one of the relatively complex components in the structures due to the fact that they must have sufficient stiffness and strength in both directions. In addition, these

columns should provide a rigid connection in both directions. This feature is not achievable by using the usual sections of the H and W shapes since they have only one strong axis. In these frames, attending both strong and weak axis bending in an intersecting segment might conduce different bending behavior contrasted with a solitary H-formed one

\* Corresponding author E-mail: hsaffari@uk.ac.ir

(Kiani et al., 2015). This drawback led to the use of sections with similar behavior in both orthogonal directions. Including these sections are cruciform sections which have the same behavior in both directions, and because of the opening of the section, performing continuity plates and beam-to-column connections are easier than the other types like box sections. Furthermore; they have a simpler constructional process. These sections usually are manufactured by two H-shaped sections. Somehow firstly, one of them is splitting into two similar T-shaped sections and then these sections and another H-shaped section are welded to each other in the middle of their webs (Figure 1).

Despite the lack of sufficient experimental research for this kind of segments, AISC

(2016) has proposed them for using in special moment resisting frames (SMRFs). They have mentioned in AISC (2016) as Flanged Cruciform Columns (FCCs). AISC relations of panel zone are derived based on H-shaped beam to column connection and for the other type of sections has emphasized engineering interpretation. In reality, there is a difference between the behaviors of these two sections in designing of panel zone. In cruciform sections, as we know two flanges which are parallel to the web have also a significant contribution in the shear capacity of the panel zone. Panel zone is a rectangular zone of the column web, which is surrounded between the continuity plates and the column flanges and have a significant role in the connection behavior (Figure 2).

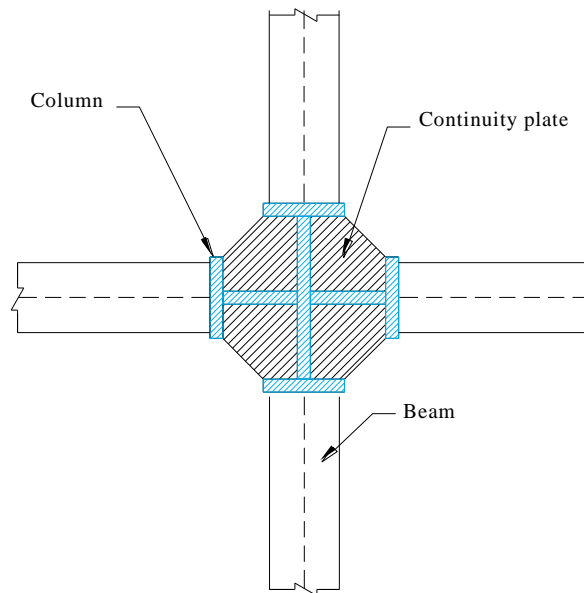

**Fig. 1.** Connection detail in the panel zone region

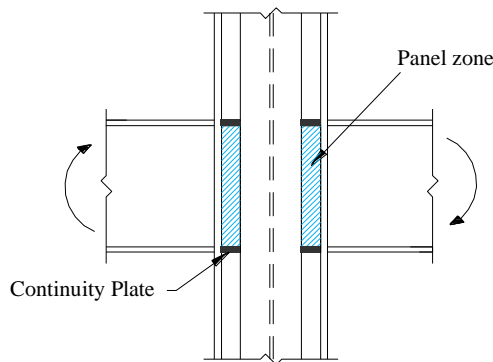

**Fig. 2.** Panel zone in steel frames

At first, Sherbourne and Jensen (1957) and Graham et al. (1960) started experimental and analytical research on the behavior of panel zone and the beam to column connection, then Krawinkler et al. (1971), Bertero et al. (1973) and Popov (1998) mentioned characteristics like high accumulate strength after yielding, large ductility, permanent hysteresis loops, and remarkable cyclic strain hardening are exist in the panel zone. The expansive damages to steel Moment Resisting Frames (MRFs) in past huge earthquakes have emphasized the need to find out the nonlinear inelastic behavior of such systems (Kasar et al., 2017).

After the Northridge earthquake in 1994, a large number of researches activity was launched at universities and related institutions to investigate damaged structures (Ibrahim et al., 2006). During these investigations, the failure factors were carefully studied. On the other hand, the standards and design criteria were also carefully reviewed in the design regulations. In these investigations, it was stated that the majority of the failures were related to the connections in the structures, and it was also explicitly stated that excessive distortion in the panel zone has a remarkable effect on failure developments in the connections. In order to raise the ductility of the pre-Northridge connections, two strategies have been suggested. The first one is strengthening the connections (Engelhard and Sabol, 1998; Kim et al., 2002) and the next is weakening the beam section (Popov et al., 1998).

Zepeda et al. (2003) investigated the cyclic behavior of four steel connections. Laboratory samples were subjected to different axial forces. The results of this study showed that the samples had a brittle behavior without significant loss of lateral capacity. Silva et al. (2004) conducted a series of experiments on two types of beam-column connections. The connections were subjected to flexural moment and axial and

compressive forces. The results of their study demonstrated that the presence of axial force has a significant effect on the behavior of the connection. Nasrabadi et al. (2013) have done comprehensive research on the evaluation of the beam to cruciform column panel zone. They suggested a new model for flanged cruciform columns by an analytical solution. The results of their proposed model depicted good agreement with FEM analyses.

Mansouri and Saffari (2014) and then Sarfarazi et al. (2016) emphasized that enhancing the ductility of the connections is not achievable unless carefully consider panel zone behavior and all the forces which play a major role in that region. Kosarieh et al. (2015) using Finite Element method by ABAQUS software considered the influence of various amount of column axial load on seismic performance of connections. They concluded that by enhancing column axial load, cyclic behavior were not considerably affected. Pan et al. (2016) conducted experimental study in order to evaluate the effect of continuity plates on shear strength of cruciform column panel zone. They reported that the continuity plates are effective in alleviation of the shear capacity of the panel zones.

Saffari et al. (2016) using Finite Element method and parametric study, proposed a mathematical model to determine the shear capacity in the cruciform columns panel zone. El-Khoriby et al. (2017) examined the effect of axial force on the performance of a series of steel beam to column connections. They noticed large values of axial force in several cases lead to remarkable effort on the connection behavior. They also asserted level and direction of the axial force might remarkably influence the connection response.

Ronga et al. (2018) using nonlinear Finite Element models (FEMs) carried a study and presented an analytical model in order to examine the effect of web and flange

thicknesses in the shear capacity of the steel tubular column panel zone. Their suggested model showed reasonably good agreement with Finite Element analysis results.

Because of the widespread use of cruciform columns in steel buildings, the study of their panel zone seems necessary. It should be noted that control relation of the panel zone in the AISC (2016) is derived from laboratory results of the H-shaped columns with a thin web. Due to the fact that two flanges of the T-shaped sections in the cruciform column are parallel to the web of H-section and resist shear, it is expected that these relations which only consider the effect of the web are not sufficiently adequate. On the other hand, most beam-to-column connections are usually subjected to the axial force. Investigating the effect of axial force variations on the behavioral characteristics of structural elements has always attracted the researchers' attention (Ebrahimi et al., 2019). The amount of axial force transmitted from the beam can greatly reduce the failure capacity of the connection. This is especially important in ordinary frames that are subject to significant horizontal loading, irregular frames at elevations that are loaded horizontally and gravity, as well as sloping frames. As a result, a detailed study of the panel zone of the cruciform column under axial force is a necessity that is evaluated in this investigation. Using the parametric Finite Elements, panel zone behavior in the cruciform columns is studied. Based on the results and by implementing excessive nonlinear Finite Element analyses, mathematical models are proposed to be applied on the linear and non-linear behavior of the panel zone.

### PANEL ZONE SHEAR STRENGTH CAPACITY IN THE AISC 2016

In recent seismic criteria defined by the AISC (2016) the nominal shear strength,  $R_n$ , of a panel zone is categorized based on the axial

forces applied to the column as follows:

a) Not considering the influence of inelastic deformation of panel zone on frame stability:

$$R_n = 0.6 F_y d_c t_{cw} \quad (1)$$

for  $P_r \leq 0.4 P_c$

$$R_n = 0.6 F_y d_c t_{cw} \left( 1.4 - \frac{P_r}{P_c} \right) \quad (2)$$

for  $P_r > 0.4 P_c$

b) Considering the influence of inelastic deformation of panel zone on frame stability:

$$R_n = 0.6 F_y d_c t_{cw} \left( 1 + \frac{3b_{cf} t_{cf}^2}{d_b d_c t_{cw}} \right) \quad (3)$$

for  $P_r \leq 0.75 P_c$

$$R_n = 0.6 F_y d_c t_{cw} \left( 1 + \frac{3b_{cf} t_{cf}^2}{d_b d_c t_{cw}} \right) \left( 1.9 - \frac{1.2P_r}{P_c} \right) \quad (4)$$

for  $P_r > 0.75 P_c$

where,  $d_c$ : is depth of the column section,  $t_{cw}$ : is web thickness of the column,  $d_b$ : is beam depth,  $b_{cf}$ : is flange width of the column,  $t_{cf}$ : is flange thickness of the column,  $P_r$ : is the factored axial force of the column and  $P_c$ : is the axial yield resistance of the column. In addition,  $F_y$ : is yield stress of the column.

### FINITE ELEMENT MODEL OF CRUCIFORM COLUMN PANEL ZONE

#### Modeling Process

To achieve a suitable model, regarding the effective parameters on the behavior of the panel zone, an extensive parametric study is carried out by ABAQUS (2013) software. These parameters consist of column web thickness ( $t_w$ ), column flange thickness ( $t_{cf}$ ), the thickness of continuity

plates ( $t_{cp}$ ) and the ratio of axial loads. Since empirical results on seismic responses of cruciform columns do not exist in the pre-qualified connections database, the results of a well-known experimental program on “SP7 of SAC01” (Lee et al., 2000), are considered in order to validate the modeling accuracy. All parametric studies were conducted for CP3, CP5 and CP7 specimens whose columns are constructed by two W-shape sections as shown in Table 1. Column sections of CP3, CP5 and CP7 are chosen from the equalization of their plastic capacity with SP3, SP5, and SP7 column sections of SAC01 (Lee et al., 2000), respectively. Beam sections are also depicted in Table 2.

Furthermore, to avoid yielding in beams before yielding in panel zone, beam sections used in CP3, CP5, and CP7 are selected in such a way that yielding in panel zone precedes beams yielding.

Poisson’s ratio ( $\nu=0.3$ ) and The Young’s modulus of elasticity ( $E=200$  GPa) were considered. Stress-strain diagram of steel is considered bi-linear (Lee et al., 2000) as seen in Figure 4. For all specimens, beam length and column length are 342.9 and 365.8 cm, respectively. Other geometric parameters of these specimens are available in Table 3. Both the shear tab and continuity plates were ASTM A36 (yield stress=250 MPa).

**Table 1.** Columns sections (all dimension in mm)

Specimen	Column section	Flange width	$t_{fo}$ (Flange thickness)	$t_{wo}$ (Web thickness)	Outside height	Yield stress (MPa)
CP3	W21x101	312.42	20.32	12.7	543.56	345
CP5	W27x146	355.6	24.765	15.367	695.96	345
CP7	W33x201	398.78	29.21	18.161	855.98	345

**Table 2.** Columns sections (all dimension in mm)

Specimen	Section	Flange width	$t_{fo}$ (Flange thickness)	$t_{wo}$ (Web thickness)	Outside height	Yield stress (MPa)
CP3	W24x68	227.84	14.86	10.54	601.2	250
CP5	W30x99	266.7	17.018	13.2	754.38	250
CP7	W36x150	304.8	23.88	15.875	911.86	250

**Table 3.** Geometric parameters of specimens

Specimen	Shear tab (mm)	No. of A325 SC bolts (mm)	$t_{cp0}$ (Continuity plate thickness) (mm)	Weld type and size (mm)	
				Beam flange	Shear tab
CP3	400x127x10	6φ22	16	CJP, root opening = 9 mm, Angle=30° and E70TG-K2	Fillet, 8mm, E70T-7
CP5	610x127x13	8φ25	19		Fillet, 8mm, E70T-8
CP7	765x127x16	10φ25	25		Fillet, 8mm, E70T-7

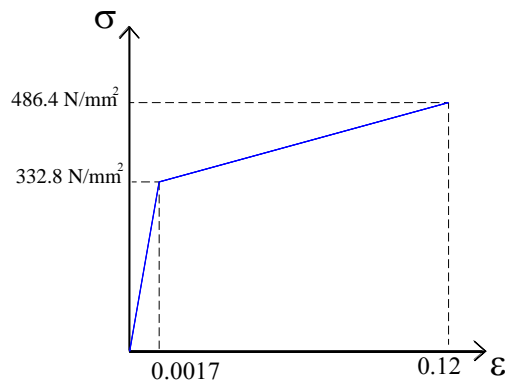

**Fig. 3.** Stress-strain diagram of steel (Lee et al., 2000)

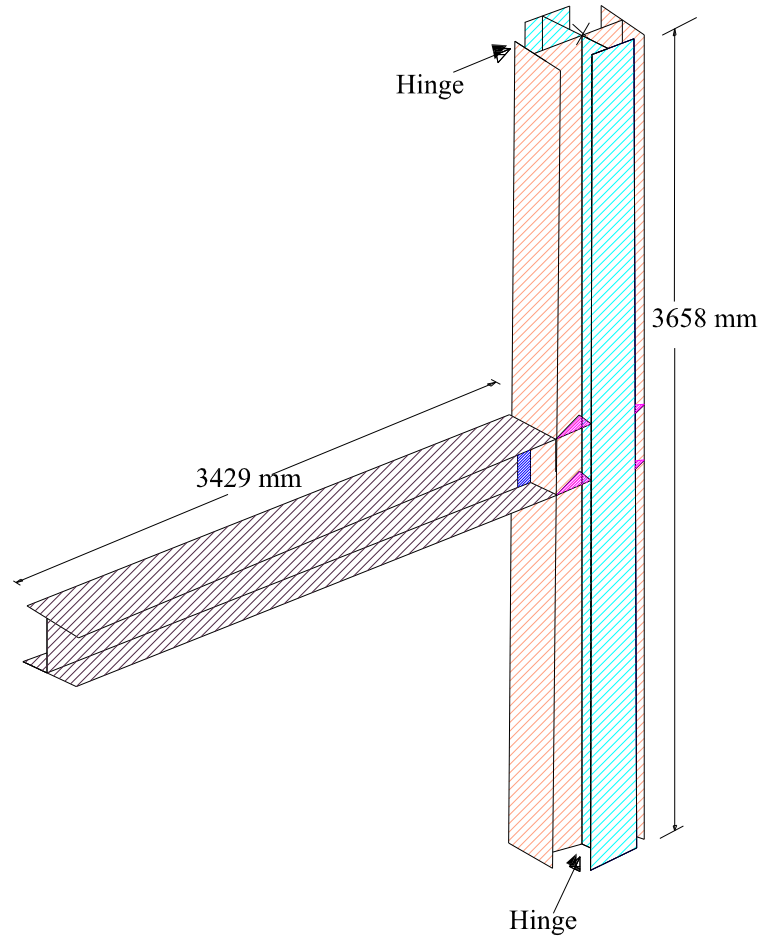

**Fig. 4.** Three-dimensionally specimen

For implementing the models in ABAQUS software (2013), shell elements (S4R) have been employed with decreased integration that the amount of integration points through the element thickness is considered five. Shell element has been used successfully in several studies (Tawil et al., 1998; Broujerdian et al., 2017; Yousaf et al., 2017; Tartaglia et al., 2018; Kosari et al., 2019). Concerning the assessment of panel zone behavior to be the major aim of this research, the specification of the beam and connection are considered elastic to guarantee yielding in the panel zone area.

To reach actual models, shear tab, and interaction between the shear tab and the beam web were modelled. However, the bolts were ignored and bolt holes just considered (Figure 5). For modelling welds and base

metals shell elements have been used and for each one, the associated material property was defined. Tie constraints are used to consider the interactions between welded component parts, so that no relative motion between the surfaces in contact would be probable. In addition, other parts of connection such as beam, column and continuity plates are merged in ABAQUS software (2013). To decrease the computational efforts, after conducting a mesh sensitivity study by keep refining the mesh until reaching no difference in FEA results, dense meshes have been used in the panel zone area, while the other areas have coarse meshes (Figure 6). Column flanges are modelled in 5 layers of elements. Imperfection value is taken into account with a factor of 1% of the beam flange thickness

from first buckling mode and distribution of geometric imperfections matched the first eigenvector of the loaded connection configuration. Incompatible with the support situations of the experimental tests (Lee et al., 2000), the ends of the column were restrained against translation only (i.e., a pinned connection) and the supports of column ends are taken into account hinged (as in experiments). The free end of the beam moves vertically under displacement control analysis and it is regarded as 230 mm.

For producing the models, thickness value for specimen's column flange,  $t_{cf}$ , is 0.75, 1, 1.25, and 1.5 times of reference specimens,  $t_{cf0}$  (Table 1). The thickness of column web specimens,  $t_{cw}$ , is equal to 0.75, 1, 1.25, times of reference specimens,  $t_{cw0}$  (Table 1). Moreover, to analyze the effect of continuity plate's thickness on panel zone behavior, the reference continuity plates thickness,  $t_{cp0}$  (table 2), has been multiplied by the values of 0.75, 1, 1.25, and finally, to consider the

effect of axial force, ratio of  $P_r/P_c$  are selected as 0.2, 0.5, 0.75 and 0.9. Therefore, total numbers of produced specimens in ABAQUS (2013) are:

432 specimens = (3 continuity plate thicknesses) × (3 column web thicknesses) × (4 column flange thicknesses) × (4 axial load ratio) × (3 specimens (CP3, CP5 and CP7))

### Shear Computing Method

To find panel zone shear force the following equation considered (Brandonisio et al., 2012):

$$V_{pz} = \frac{M_b}{h_t} (1 - \rho) \quad (5)$$

where  $h_t = d_b - t_{bf}$ ,  $\rho = \frac{h_t}{H - d_b}$ ,  $t_{bf}$  is the beam flange thickness,  $d_b$  is the depth of the beam cross-section,  $M_b$  is the moment in the beam and  $H$  is the average value of the story heights.

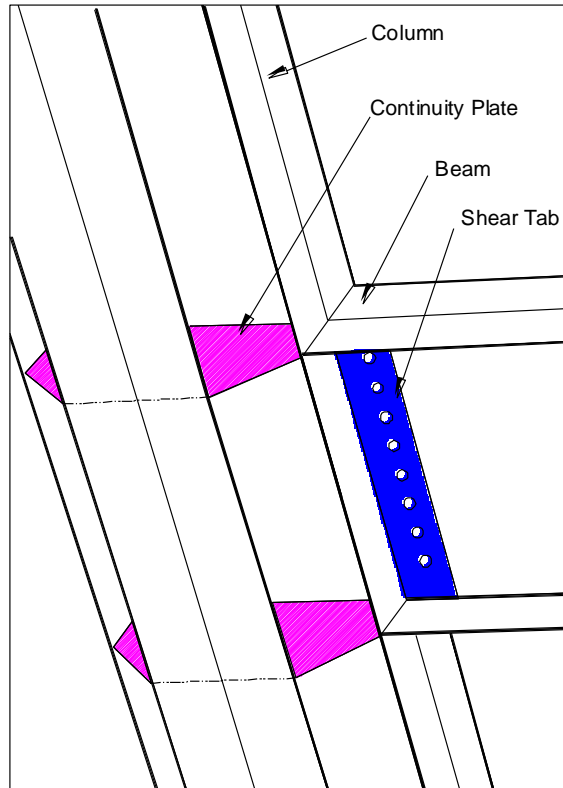

Fig. 5. Sample connection detail



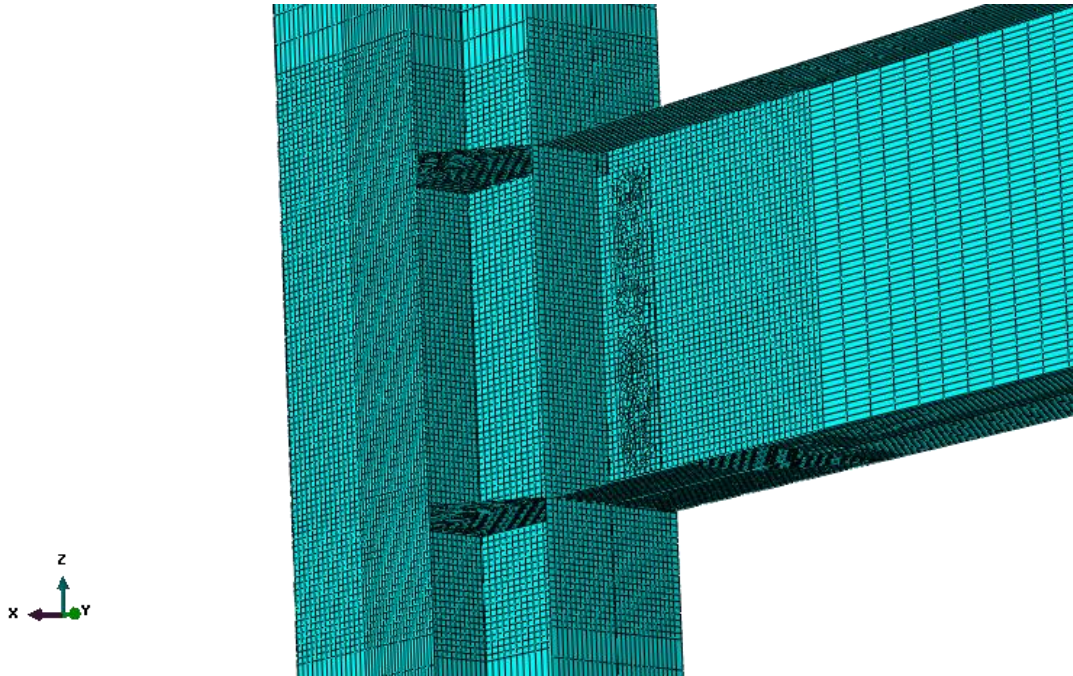

Fig. 6. Finite Element modeling

### Calculating Panel Zone Distortion

The suggested formula by Ricles et al. (2004) is used to obtain the panel zone distortion:

$$\gamma = \frac{\Delta^+ - \Delta^-}{2} \frac{\sqrt{d_{pz}^2 + b_{pz}^2}}{d_{pz} b_{pz}} \quad (6)$$

where  $\Delta^+$  and  $\Delta^-$ : diagonal deformations of panel zone, and  $d_{pz}$  and  $b_{pz}$ : are vertical and horizontal dimension of panel zone,

respectively (Figure 7).

### Verification of Study

To verify the results, specimen SP7 (Lee et al., 2000) is modeled by the ABAQUS software (Figure 8). The free end of the beam moves vertically under displacement control analysis and the results are compared with those in experiments. As seen from Figure 9, outcomes of the SP7 modeling in finite element simulation are in good agreement with those obtained in experiments.

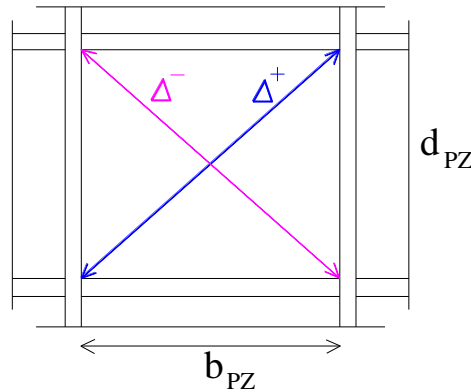

Fig. 7. Geometry of panel zone to obtain panel zone distortion (Ricles et al., 2004)



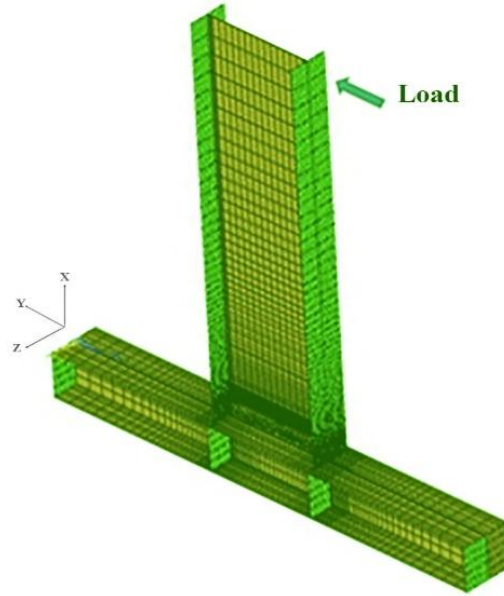

Fig. 8. Finite Element model of specimen

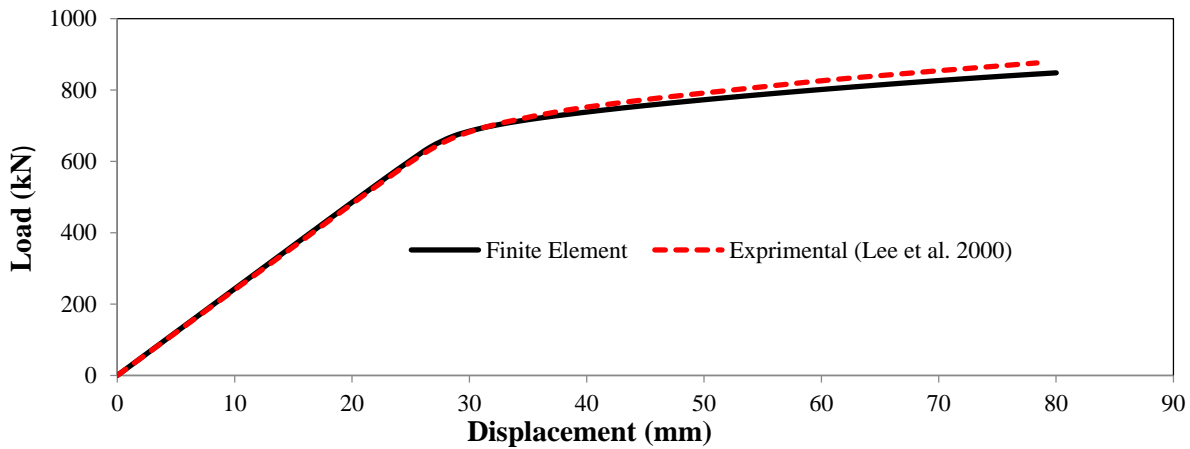

Fig. 9. Comparing experimental results and finite element modeling results for specimen SP7

## PROPOSED ANALYTICAL MODEL

### Proposing a New Relation for Yield Capacity of the Panel Zone

Shear capacity and demand of the panel zone must be analyzed at the design process to confirm proper response. (Tuna and Topkaya, 2015). In this section, a new mathematical model considering axial force is proposed, in a way which can provide acceptable results for a wide range of column-sectional dimensions. There are several methods to obtain panel zones shear strength

of the columns. In some of these methods the shear yield strength of panel zone is expressed as follows;

$$V_y = \tau_y A_v \quad (7)$$

where  $A_v$ : is the shear area of column section and  $\tau_y$ : is the shear yield stress of column section.

The effective shear area in the cruciform section is shown by black, dotted and crossed areas in Figure 10 (Saffari et al., 2016)

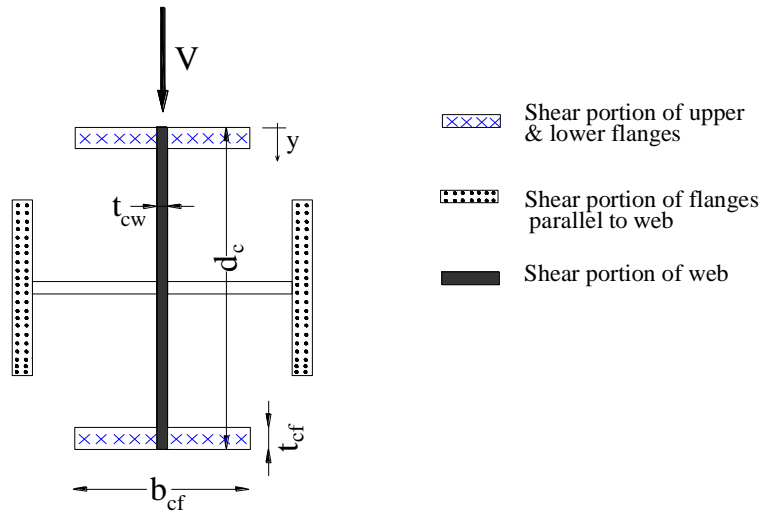

**Fig. 10.** Portion of shear force resisted by web and flanges (Saffari et al., 2016)

But due to the ease of possibility of comparing the results of present study with ones of AISC relationships and also other previous studies, which are mainly based on the I and H shape columns, at which the shear is tolerated only by the web, in the following the shear portion of web from total shear exerted for a cross section will calculate and the relationships will be proposed based on this. Figure 11, shows the various shear areas considered in three different models.

Figure 11a depict the shear area considered by the AISC (2016) Code of Standard Practice that is equal to  $(A_v=d_c.t_{cw})$ . Figure 11b also displays the shear area adopted by Wang (1988) whose value equals. Figure 11c represents the area considered by Krawinkler (1971) that is equal to  $(d_c-2t_{cf}).t_{cw}$ , in the above relationships,  $t_{cw}$  is the web thickness of the column; and the rest of the parameters were previously defined. Both

Wang (1988) and Krawinkler (1971) have presented the yield shear stress according to the Von Mises criterion in accordance with the following relation.

$$\left(\frac{P_r}{A}\right)^2 = F_y^2 - 3\tau^2 \tag{8}$$

The portion of the shear force resisted by the web for a cruciform section can be determined using  $V_i = \frac{V}{I_t} \int Q_i dA_i$  formula. Saffari et al. (2016) calculated the shear portion of web from total shear exerted for a cross-section as follows:

$$\lambda V_y = V_{0y} \tag{9}$$

$$\lambda = 1 - \frac{(3\alpha - 2\alpha^2) + \beta^2}{3 + \beta^2} \tag{10}$$

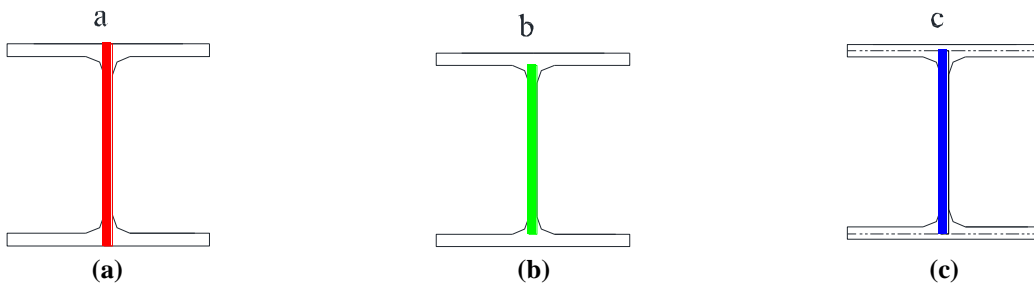

**Fig. 11.** The considered shear area: a) AISC (2016); b) Wang (1988); c) Krawinkler (1971)

in which  $\alpha$  and  $\beta$  consist of:

$$\alpha = \frac{t_{ef}}{d_c}, \quad \beta = \frac{b_{ef}}{d_c} \quad (11)$$

Analysis of 432 cruciform column panel zone models is shown that the shear yield strength obtained by Krawinkler (1971) for  $P \leq 0.5P_y$  is close to Finite Elements results. Nevertheless, for  $P > 0.5P_y$ , the Krawinkler model underestimates the shear yield strength. Considering the finite element analysis, in the present study the shear yield strength is presented by the following formula;

$$V_y = \frac{1}{\lambda} 0.6F_y d_c t_{cw} \alpha \quad (12)$$

where the coefficient  $\alpha$ , which is then called the coefficient of reduction of resistance caused by the axial load (R.F.), is:

$$\alpha = \sqrt{1 - \left(\frac{P_r/A}{F_y}\right)^2} \quad \text{For } \frac{P}{P_y} \leq 0.5 \quad (13)$$

$$\alpha = 1.12 - 0.5 \frac{P}{P_y} \quad \text{For } \frac{P}{P_y} > 0.5$$

As demonstrated in Eqs. (3-4) the decreasing coefficient in the AISC Code of Standard Practice is as follows:

$$\alpha_A = 1 \quad \text{For } \frac{P}{P_y} \leq 0.75$$

$$\alpha_A = \left(1.9 - 1.2 \frac{P}{P_y}\right) \quad \text{For } \frac{P}{P_y} > 0.75$$

Moreover, the amount of the decreasing coefficient in the Von Mises theory is as follows:

$$\alpha_v = \left(\sqrt{1 - \left(\frac{P}{P_y}\right)^2}\right) \quad (14)$$

Comparison between the adopted decreasing coefficient in the proposed relation, the AISC code and that suggested by Von Mises relationship is presented in Figure 12. It should be noted that  $\alpha$  in AISC code (2016) has derived based on I shaped columns, while the ones have been proposed in this study is obtained for cruciform sections. The purpose of comparing them is to illustrate the need of proposing new relation for sections like cruciform which are neglected in guidelines.

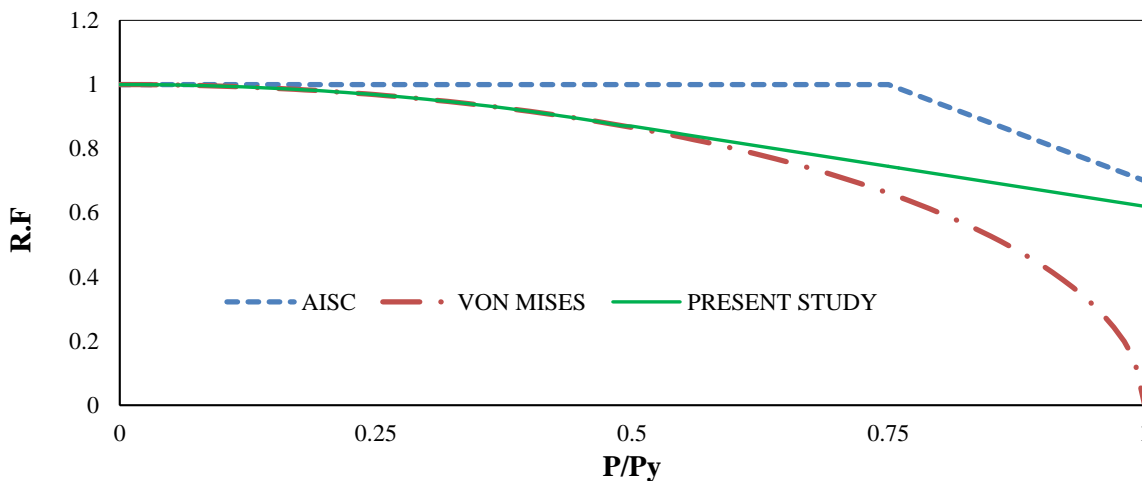

Fig. 12. The comparison between the adopted decreasing coefficient in the proposed formula with the AISC and the Von Mises formula

### Yield Shear Strain of Panel Zone

By combination of shear and Von Mises stress criteria, the shear strain of panel zone obtained as follows:

$$\left(\frac{P_r}{A}\right)^2 = F_y^2 - 3\tau_y^2 \rightarrow \tau_y = \frac{\sqrt{F_y^2 - (P_r/A_c)^2}}{\sqrt{3}}$$

$$\tau_y = G\gamma_y \rightarrow \gamma_y = \frac{\sqrt{F_y^2 - (P_r/A_c)^2}}{G\sqrt{3}} \quad (15)$$

After the calculation of the yield shear strength and strain of the panel zone, the only remaining unknown parameter, i.e.  $K_y$ , is calculable, using:

$$K_y \cdot \gamma_y = V_y \quad (16)$$

By Substituting the Eqs. (12) and (15) in Eq. (16), the panel zone initial stiffness ( $K_y$ ) can be derived as follows:

$$K_y \cdot \gamma_y = V_y \rightarrow K_y = \frac{1.039 G d_c t_{cw} \alpha}{\lambda \sqrt{1 - (P_r/P_y)^2}} \quad (17)$$

### Inelastic Behavior of the Panel Zone

The surrounding elements of the panel zone continuity plates and column flanges help to enhance the shear resistance. It should

be mentioned that this only occurs when the continuity plates exist. The plastic moment of the column flange ( $M_{y,cf}$ ) is, equals to (Brandonisio, 2012):

$$M_{y,cf} = F_{y,cf} \frac{b_{cf} t_{cf}^2}{4} \alpha_v \quad (18)$$

Consequently, the shear strength increment of the panel zone in the inelastic region ( $\Delta V_{PZ}$ ), will be obtained as follows (Brandonisio, 2012):

$$\Delta V_{PZ} = \frac{M_{y,cf}}{h_t} = \frac{F_{y,cf} b_{cf} t_{cf}^2}{h_t} \alpha_v \quad (19)$$

where,  $b_{cf}$  is the flange width of the column, and  $F_{y,cf}$  is the yield stress of the flange materials of the column; the rest of the parameters are defined as before.

Details of the shear strength increment caused by the boundary elements contribution are shown in Figure 13. It is necessary to notice that the ultimate shear strain, according to the suggestions of Krawinkler (1978) and Lin et al. (2000) is assumed four times the yield shear strain ( $\gamma=4\gamma_y$ ) because of the contribution of the shear force boundary elements related to the shear strain.

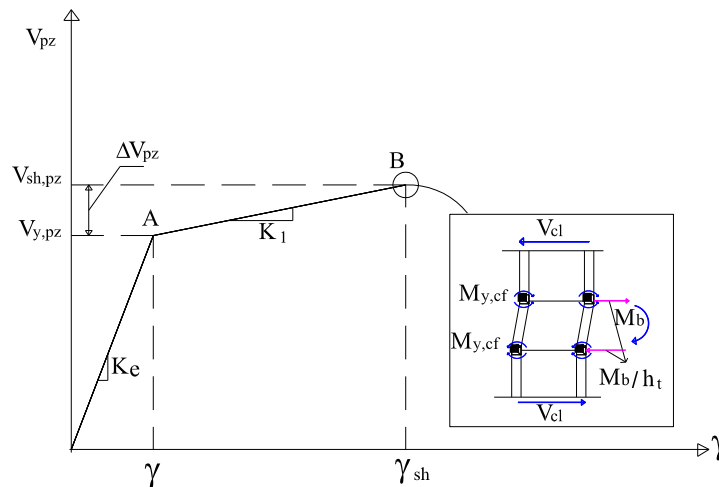

Fig. 13. Shear resistance increment of the PZ resulted from the Boundary Elements contribution (Lin et al., 2000)

According to the presented relationships in the AISC code of Standard Practice, the amount of increment in the shear force in the inelastic region is considered as follows:

$$\Delta V_{PZ} = \frac{1.8F_y b_{cf} t_{cf}^2}{d_b} \alpha_A \quad (20)$$

The amount considered by Krawinkler (1971) is as follows:

$$\Delta V_{PZ} = \frac{1.8f_y b_{cf} t_{cf}^2}{h_t} \alpha_v \quad (21)$$

Also, the amount considered by Wang (1988) is given in the following relationship:

$$\Delta V_{PZ} = \frac{1.01f_y b_{cf} t_{cf}^2}{h_t} \alpha_v \quad (22)$$

As indicated by the models, in all of these models, the amount of shear force added due to the participation of the boundary elements is greater than 1.0.

The results of the Finite Elements parametrical studies show that the coefficient for applying the shear resistance increment caused by the boundary elements is 1.6; consequently, the shear force increment of the district after the elastic district is obtained as

follows:

$$\Delta V_{PZ} = \frac{1.6f_y b_{cf} t_{cf}^2}{h_t} \alpha \quad (23)$$

Thus, the ultimate shear strength of the panel zone  $V_{sh,pz}$ , results as follows:

$$V_{sh,pz} = V_{y,pz} + \Delta V_{PZ} \quad (24)$$

Placing Eqs. (12) and (23) into Eq. (24), the result is obtained by the following relationship.

$$V_{sh,pz} = \frac{1}{\lambda} 0.6F_y d_c t_{cw} \alpha + \frac{1.6f_y b_{cf} t_{cf}^2 \cdot \alpha}{h_t} \quad (25)$$

The stiffness of the panel zone in the inelastic region, ( $K_{sh}$ ) is obtained as follows:

$$K_{sh} = \frac{\Delta V_{PZ}}{3\gamma_y} \quad (26)$$

To illustrate the accuracy of the presented relationships, the mathematical model has been compared with the finite element results for CP3, CP5 and CP7 cruciform specimens (Figure 14).

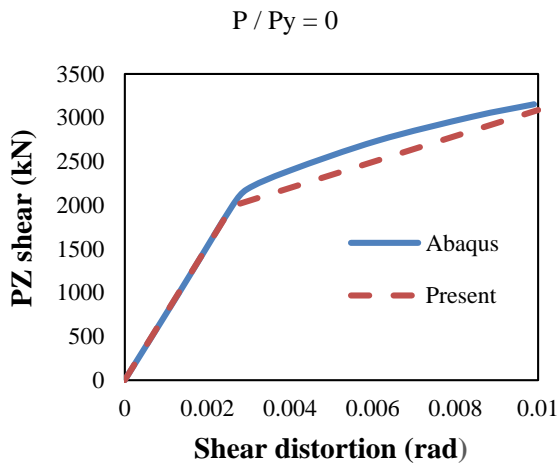

(a) Sample No.1, (CP3)

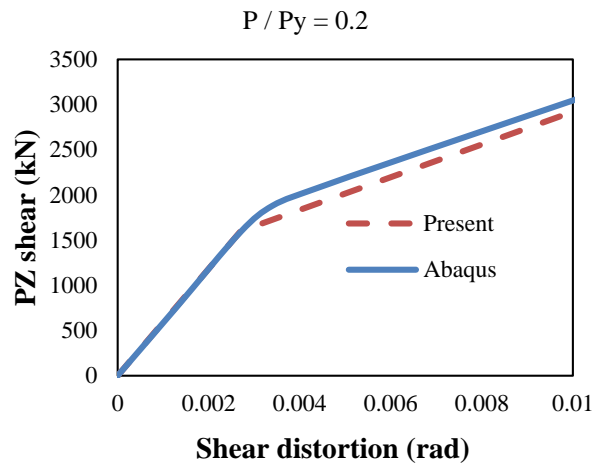

(b) Sample No. 2, (CP3)

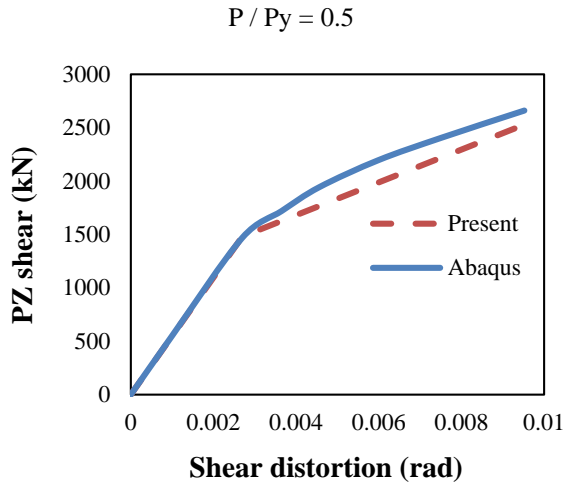

(c) Sample No. 3, (CP3)

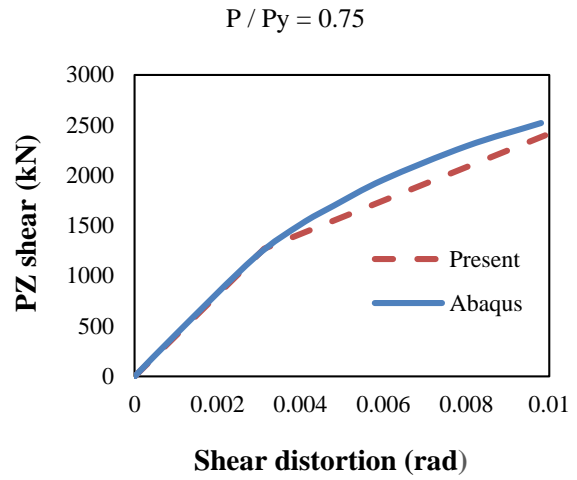

(d) Sample No. 4, (CP3)

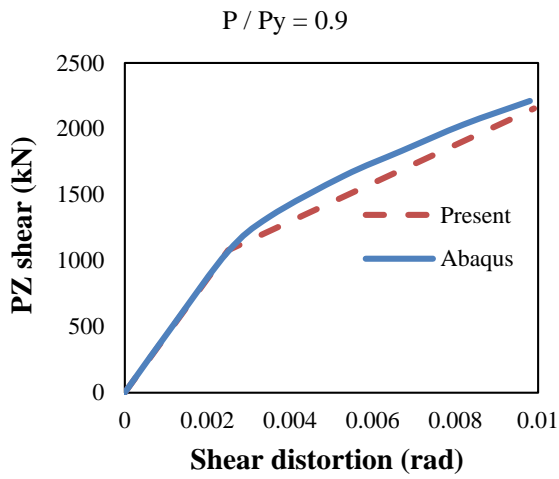

(e) Sample No. 5, (CP3)

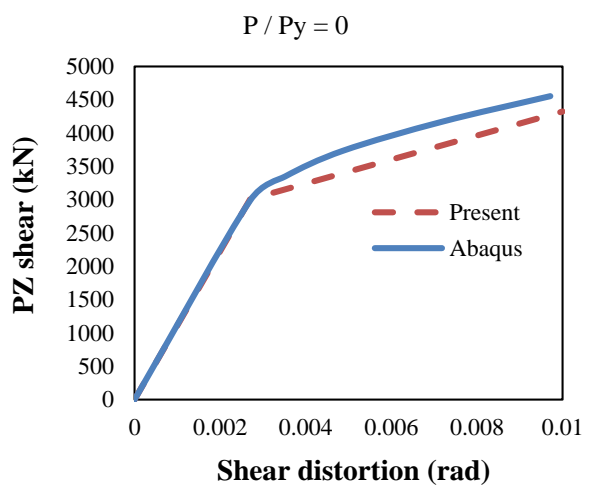

(f) Sample No. 6, (CP5)

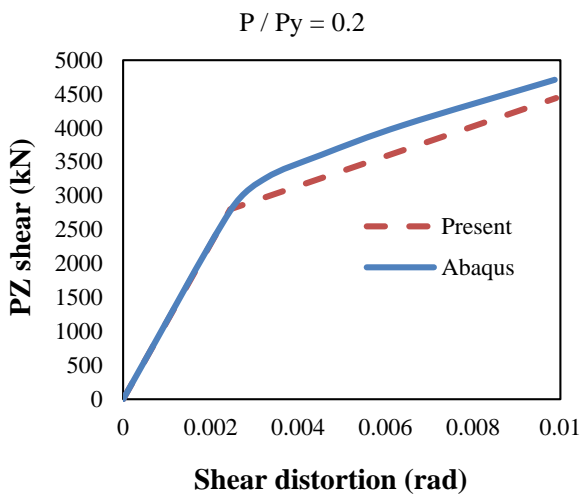

(g) Sample No.7, (CP5)

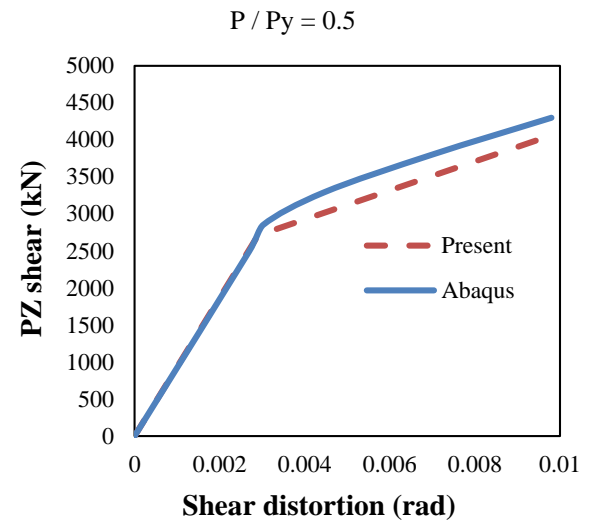

(h) Sample No. 8, (CP5)

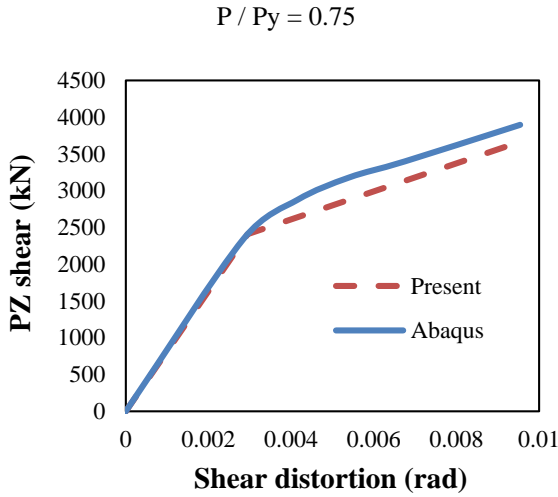

(i) Sample No. 9, (CP5)

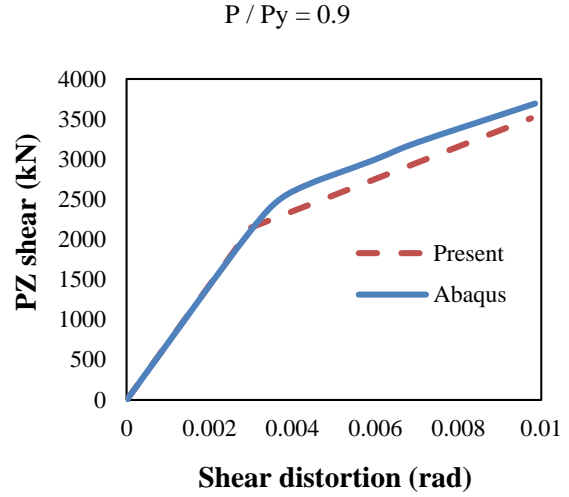

(j) Sample No. 10, (CP5)

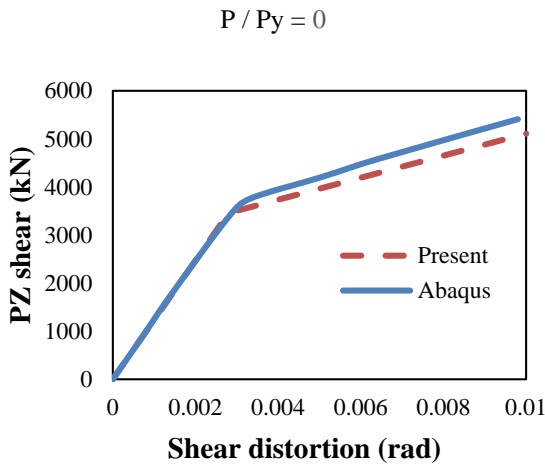

(k) Sample No. 11, (CP7)

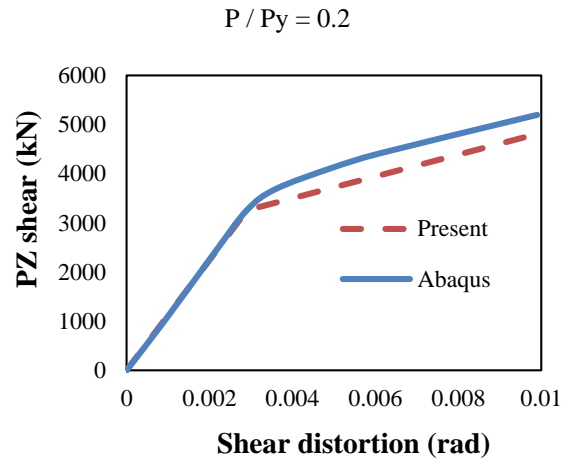

(l) Sample No. 12, (CP7)

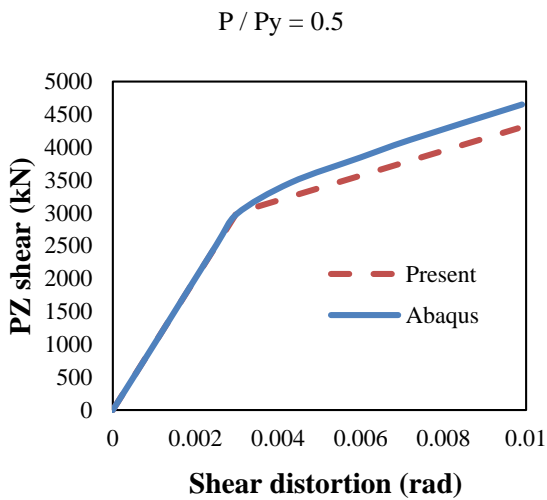

(m) Sample No. 13, (CP7)

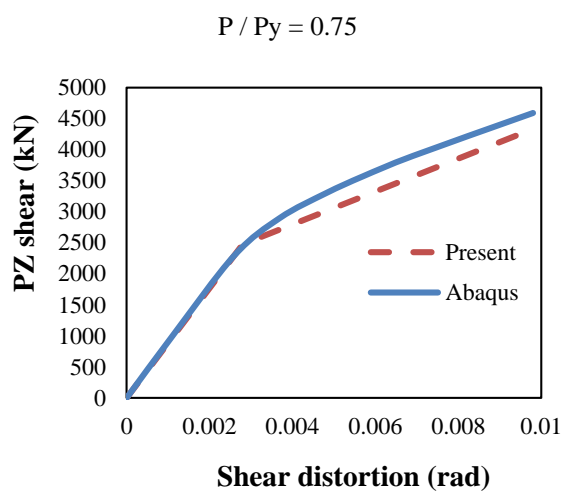

(n) Sample No. 14, (CP7)



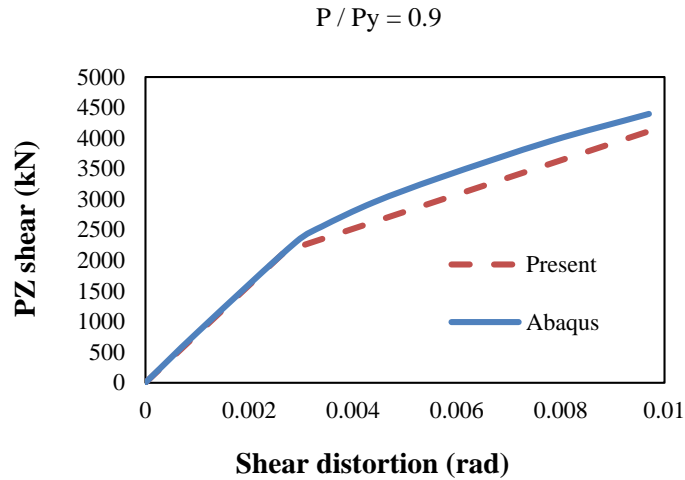

(o) Sample No. 15, (CP7)

**Fig. 14.** Comparison of the results by presented relationships and those by ABAQUS

As seen in Figure 14, the new model proposes reasonable results for a wide range of columns. Additionally, Finite Element analysis reveals that the thickness of continuity plates has slight efficacy on shear capacity of panel zone.

In order to present all of the results of finite element simulation, changes of column flange thickness in non-dimensional yield capacity ( $V_y/V_{ABAQUS}$ ) for CP3, CP5, and CP7 are shown in Figures 15-17.

As demonstrated in figures above, the general trend of diagrams is upward which seems reasonable, as the thickness of flange and web in manufactured specimens is

growing. This leads to increasing the value of ( $V_y/V_{ABAQUS}$ ) for different specimens and increases deviation of the proposed relation in estimating yield shear capacity. Nevertheless, the deviation rate is always in an acceptable range whose value will be presented in following states.

### Comparing the Accuracy of Different Methods

Tables 3 and 4 indicate the accuracy of the presented relations for estimating yield capacity and ultimate capacity of panel zone. As seen from these tables the introduced model in this study has a good performance.

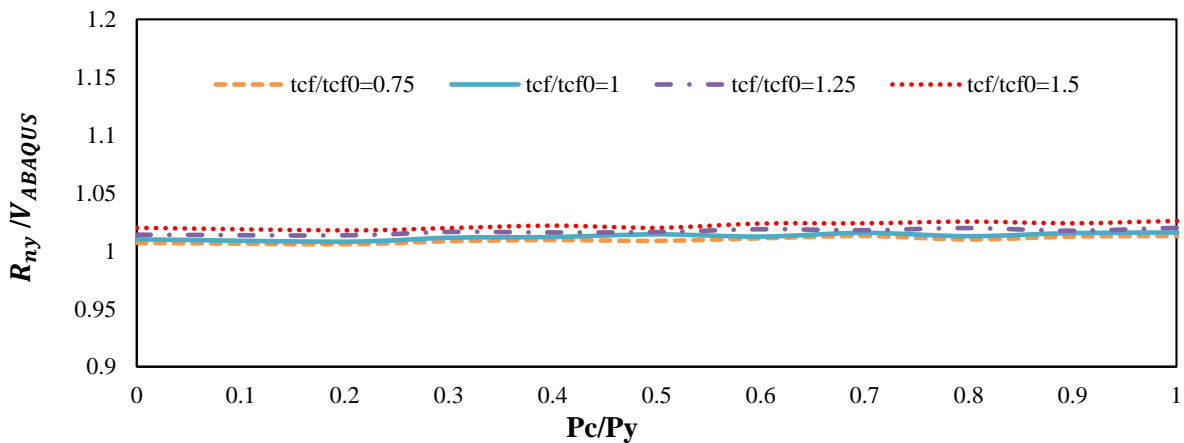

**Fig. 15.** Variations of column flange thickness in non-dimensional shear yield strength of panel zone in generated specimens from CP3

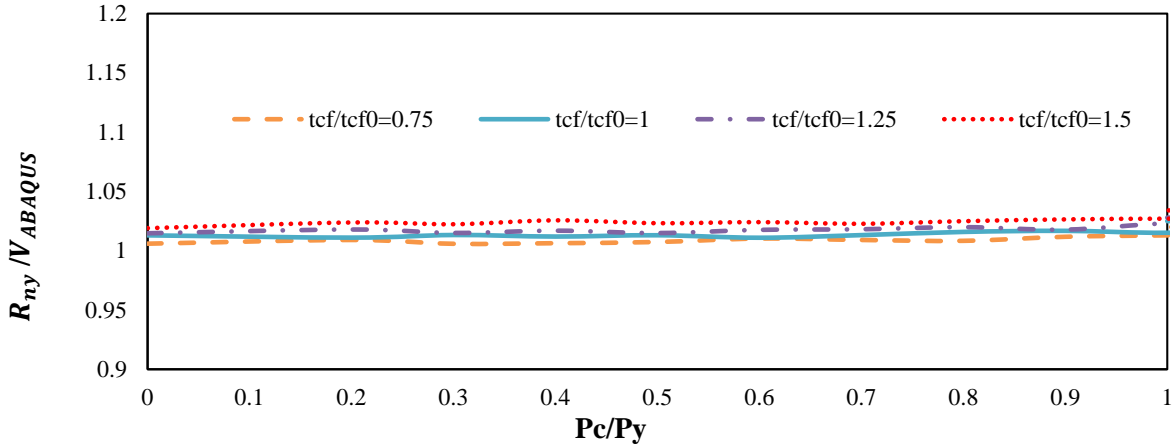

Fig. 16. Variations of column flange thickness in non-dimensional shear yield strength of panel zone in generated specimens from CP5

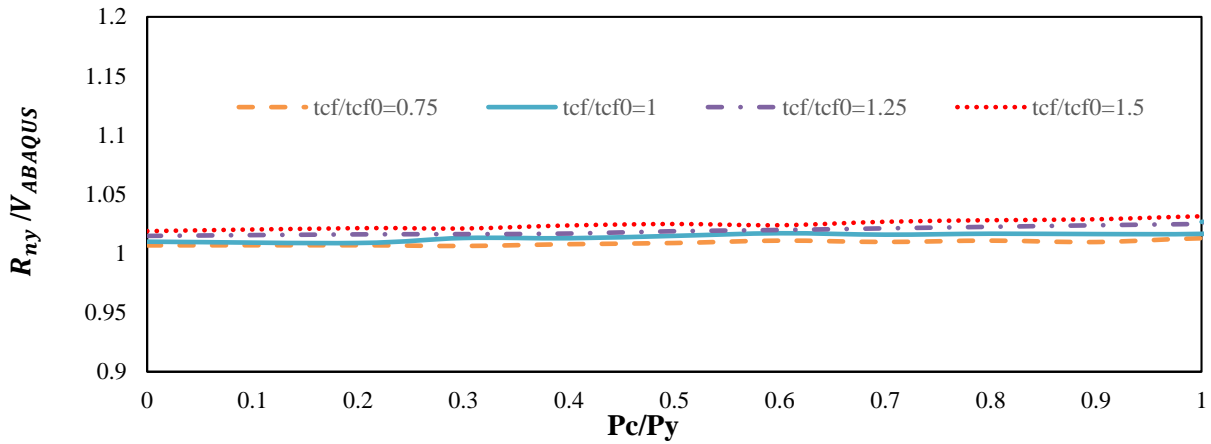

Fig. 17. Variations of column flange thickness in non-dimensional shear yield strength of panel zone in generated specimens from CP7

Table 4. Deviation in 432 Finite Element samples for estimating yield capacity of the panel zone

Deviation	Proposed model
Average deviation (%)	5.32
Max deviation (%)	8.12

Table 5. Deviation in 432 Finite Element samples for estimating ultimate capacity of panel zone

Deviation	Proposed model
Average deviation (%)	6.2
Max deviation (%)	8.44

## SUMMARY AND CONCLUSIONS

Regarding the importance of the cruciform columns in the MRFs in seismic areas, the presentation of a mathematical model for the panel zones of these columns that would estimate the behavior of their panel zones

with higher accuracy seems crucial. In this study a new mathematical model is presented to define panel zone behavior of cruciform column section including axial force effect. Extensive parametric finite-element analyses were conducted to validate the mathematical relation. The models are analyzed by

ABAQUS and carrying out wide range nonlinear Finite Element analysis. This parametric study is performed in which efficient factors on cruciform column panel zone such as thickness of column web and flange, thickness of continuity plates and also the axial force are taken into account.

As seen in Figure 14, for a wide range of columns, the new mathematical relations propose reasonable results. Beside this, Finite Element analysis demonstrate that the effect of the thickness of continuity plates on shear capacity of panel zone is slightly and negligible. Also changes of column flange thickness in non-dimensional yield capacity ( $V_y/V_{ABAQUS}$ ) for CP3, CP5, and CP7 specimens in Figures 15-17 show an upward trend. This leads to increasing the value of ( $V_y/V_{ABAQUS}$ ) for different specimens and increases deviation of the proposed relation in estimating yield shear capacity. Average deviation rates with values 5.32% and 6.2% respectively for estimating yield capacity and ultimate capacity of the panel zone are always in an acceptable range and demonstrate that suggested relations are well-matched with the outcomes of Finite Element results which showing the precision, simplicity, and capability of the suggested model.

Moreover, ignoring to consider the thickness of the column's web and flanges in the equation of the yield shear strain in some cases led to large value of deviation. In the proposed relationship for the yield shear strain of panel zone, these parameters have interfered and this led to a reduction in deviation. Finally, it should be noted that in most previous studies, the axial load has not been considered in the experiments. However, in the parametric studies carried out in this study, the axial load has changed in a large range and hence the proposed relationships can be used for wide range of axial loads which has been exerted on the column. However it seems for confirming the behavior and shear capacity of cruciform

columns panel zone, more analytical and experimental investigations should be carried out.

## REFERENCES

- AISC, American Institute of Steel Construction. (2016). *Seismic provisions for structural steel buildings*, AISC 341-16, Chicago, IL.
- AISC, American Institute of Steel Construction. (2016). *Specification for structural steel buildings*, AISC 360-16, Chicago, IL.
- Bertero, V.V., Krawinkler, H. and Popov, E.P. (1973). *Further studies on seismic behavior of steel beam-to-column subassemblages*, EERC Report No. 73-27, University of California, Berkeley, CA, USA.
- Brandonisio, G., De Luca, A. and Mele, E. (2012). "Shear strength of panel zone in beam-to-column connections", *Journal of Constructional Steel Research*, 71, 129-142.
- Broujerdian, V., Shayanfar, M.A. and Ghamari, A. (2017). "Corner crack effect on the seismic behavior of steel plate shear wall system", *Civil Engineering Infrastructures Journal*, 50(2), 311-332.
- Ebrahimi, E., Abdollahzadeh, G.R. and Jahani, E. (2019). "The effect of axial force variations on nonlinear modeling and seismic response of reinforced concrete structures", *Civil Engineering Infrastructures Journal*, 52(2), 379-395.
- El-Khoriby, S., Sakr, M. A., Khalifa T. M. and Eladly M.M. (2017). "Modelling and behavior of beam-to-column connections under axial force and cyclic bending", *Journal of Constructional Steel Research*, 129, 171-184.
- El-Tawil, S., Mikesell, T., Vidarsson, E. and Kunnath, S. (1998). *Strength and ductility of FR welded-bolted connections*, Report No. SAC/BD-98/01, Applied Technology Council, Redwood City, California.
- Engelhard, M.D. and Sabol, T.A. (1998). "Reinforcing of steel moment connections with cover plates: benefits and limitations", *Engineering Structures*, 20(4), 510-520.
- Graham, J.D., Sherbourne, A.N., Khabbaz, R.N. and Jensen, C.D. (1960). "Welded interior beam-to-column connections", *Welding Research Council*, 63, 1-28.
- Ibrahim S.A., El-Dakhkhni W.W. and Elgaaly M. (2006). "Behavior of bridge girders with corrugated webs under monotonic and cyclic loading", *Engineering Structures*, 28(14), 1941-55.
- Kasar, A., Bharti, S.D., Shrimali, M.K. and Goswami, R. (2017). "Mechanics based force-deformation curve of steel beam to column moment joints",

- Steel and Composite Structures*, 25(1), 19-34.
- Kiani, B.K., Torabian, S. and Mirghaderi S.R. (2015). “Local seismic stability of flanged cruciform sections (FCSs)”, *Engineering Structures*, 96, 126-138.
- Kim, T., Whittaker, A., Gilani, A., Bertero, V. and Takhirov, S. (2002). “Cover-plate and flange-plate steel moment-resisting connections”, *J. Structural Engineering*, 128(4), 474-482.
- Kosari, E., Poursha, M. and Abedi, K. (2019). “Seismic evaluation of tall unstiffened Steel Plate Shear Wall (SPSW) systems with emphasis on reversal phenomenon in the higher mode pushover curve”, *International Journal of Civil Engineering*, 17 (5), 523-540.
- Kosarieh, A.H., Danesh, F. and Shiri, R. (2015). “Column axial load effects on performance of panel zone in welded-flange-plate connections”, *Advances in Structural Engineering*, 18(6), 775-789.
- Krawinkler, H. (1978). “Shear in beam-column joints in seismic design of steel frames”, *Engineering Journal*, AISC, 5(3), 82-91.
- Krawinkler, H., Bertero, V.V. and Popov, E.P. (1971). *Inelastic behavior of steel beam-to-column subassemblages*, EERC Report No. 71-7, University of California, Berkeley, CA, USA.
- Lee, K.H., Stojadinovic, B., Goel, S.C., Margarin, A.G., Choi, J., Wongkaew, A., Reyher, B.P. and Lee, D.Y. (2000). “Parametric tests on unreinforced connections”, *SAC Background Document*, SAC/BD-00/01, SAC Joint Venture, Richmond, CA, USA.
- Lin, K.C., Tsai, H.C., Kong, S.L. and Hsieh, S.H. (2000). “Effect of panel zone deformations on cyclic performance of welded moment connections”, *XII WCEE*, New Zealand, Document No. 1252.
- Mansouri, I. and Saffari, H. (2014). “A new steel panel zone model including axial force for thin to thick column flanges”, *Steel and Composite Structures*, 16 (4), 417-436.
- Nasrabadi, M.M., Torabian, S. and Mirghaderi, S.R. (2013). “Panel zone modelling of flanged cruciform columns: An analytical and numerical approach”, *Engineering Structure*, 49, 491-507.
- Pan, L., Chen, Y., Chuan, G., Jiao, W. and Xu, T. (2016). “Experimental evaluation of the effect of vertical connecting plates on panel zone shear stability”, *Thin-Walled Structures*, 99, 119-131.
- Popov, E.P., Yang, T.S. and Chang, S.P. (1998). “Design of steel MRF connections before and after 1994 Northridge earthquake”, *Engineering Structures*, 20(12), 1030-1038.
- Ricles, J.M., Zhang, X., Lu, L.W. and Fisher J.W. (2004). *Development of seismic guidelines for deep-column steel moment connections*, ATLSS Report No. 04-13.
- Ronga, B., Liua, S., Yana, J.B. and Zhanga, R. (2018). “Shear behavior of panel zone in through-diaphragm connections to steel tubular columns”, *Thin-Walled Structures*, 122, 286-299.
- Saffari, H., Sarfarazi, S. and Fakhraddini, A. (2016). “A mathematical steel panel zone model for flanged cruciform columns”, *Steel and Composite Structures*, 20(4), 851-867.
- Sarfarazi, S., Fakhraddini, A. and Modaresahmadi, K. (2016). “Evaluation of panel zone shear strength in cruciform columns, box columns and double- web columns”, *International journal of structural and civil engineering research*, 5(1), 52-56.
- Sherbourne, A.N. and Jensen, C.D. (1957). *Direct welded beam column connections*, Report. No. 233.12, Fritz Laboratory, Lehigh University, Bethlehem, Pennsylvania.
- Silva, L. D., Lima, L., Vellasco, P. and Andrade, S. (2004). “Behaviour of flush endplate beam-to-column joints under bending and axial force”, *Steel and Composite Structures*, 4(2), 77-94.
- SIMULIA, ABAQUS. (2013). *Analysis and theory manuals*, Providence (RI, USA): SIMULIA, the Dassault Systèmes, Realistic Simulation.
- Tartaglia, R., D’Aniello, M., Rassati, G., Swanson, J. and Landolfo, R. (2018). “Full strength extended stiffened end-plate joints: AISC vs recent European design criteria”, *Engineering Structures*, 159, 155-171.
- Tuna, M. and Topkaya, C. (2015). “Panel zone deformation demands in steel moment resisting frames”, *Journal of Constructional Steel Research*, 110, 65-75.
- Wang, M., Shi, Y., Wang, Y., and Shi, G. (2013). “Numerical study on seismic behaviors of steel frame endplate connections”, *Journal of Constructional Steel Research*, 90, 140-152.
- Wang, S.J. (1988). “Seismic response of steel building frames with inelastic joint deformation”, Lehigh University.
- Yousaf, M., Siddiqi, Z.A., Sharif, M.B. and Qazi, U. (2017) “Force- and displacement-controlled non-linear FE analyses of RC beam with partial steel bonded length”, *International Journal of Civil Engineering*, 15(4), 499-513.
- Zepeda, J.A., Itani, A.M. and Sahai, R. (2003). “Cyclic behavior of steel moment frame connections under varying axial load and lateral displacements”, *Journal of Constructional Steel Research*, 59, 1-25.